

8,11-Dichloro-*N*-tosyl-3-aza[5]metacyclophane: A Highly Strained Aromatic System

Daniël S. van Es, Arne Egberts, Stephen Nkrumah, Hans de Nijs, Willem H. de Wolf, and Friedrich Bickelhaupt*

Scheikundig Laboratorium, Vrije Universiteit De Boelelaan 1083, NL-1081 HV Amsterdam, The Netherlands

Nora Veldman and Anthony L. Spek

Vakgroep Kristal en Structuurchemie Universiteit Utrecht, Padualaan 8 NL-3584 CH Utrecht, The Netherlands

Received October 7, 1996

Small cyclophanes are challenging for their interesting properties as well as for their difficult synthetic accessibility. In 1984 we reported the X-ray crystal structure of the smallest isolable [*n*]metacyclophane at that time: 8,11-dichloro[5]-metacyclophane (**1**).¹ Its benzene ring displayed a severe boatlike distortion induced by the short pentamethylene chain, which is reflected in a high reactivity. Despite this distortion, the bond distances have normal aromatic values (1.389(3)–1.400(3) Å) without cyclohexatriene-like bond alternation. The introduction of a heteroatom such as nitrogen in the bridge was expected to increase the distortion of the benzene ring by shortening the bridge, due to the shorter nitrogen–carbon bond distance; in addition, a strained heteraphane with potentially interesting interactions between the heteroatom and the aromatic ring might be expected. Relatively few small hetero[*n*]metacyclophanes are known. The first reference goes back to 1919 with the (now questionable) synthesis of an aza[7]metacyclophane.^{2a} In 1985, Shea and co-workers reported the syntheses of various oxal[7]- and oxal[6]metacyclophanes.^{2b} We here report the synthesis of a substituted 3-aza[5]metacyclophane, so far the smallest heterometacyclophane known.

Starting from diester **2**,^{3,4} the bistosylate **3** was prepared in two steps.⁵ Ring closure of **3** with *N*-tosylamide yielded **4** in a yield of 48% (Scheme 1). Dichlorocarbene addition to **4** gave the spiro compound **5**. This was converted to **6** by flash vacuum thermolysis. Dichlorocarbene addition to **6** yielded the propellane **7**. Treatment of **7** with potassium *tert*-butoxide gave the desired cyclophane **8** by double elimination of hydrogen chloride with concomitant opening of the three-membered ring, in analogy to the synthesis of **1**.¹

In view of the expected higher strain in **8**, it was of special interest to compare its X-ray crystal structure⁶ (Figure 1) with that of its carbon analogue **1**. Surprisingly both the bow (α) and the stern (γ) of the benzene ring of **8** are only slightly more distorted than those of **1** (α , 27.4(3)° versus 26.8°; γ , 12.3(4)° versus 12.0°, respectively). Also, the projected angle β of the benzylic methylene groups with the plain of the four central

Scheme 1^a

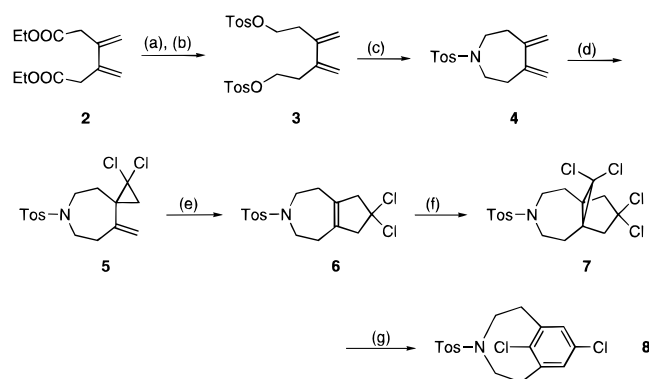

^a (a) LiAlH₄, ether (anhydrous), 6 h, reflux; (b) TsCl, pyridine, 18 h, 0 °C; (c) H₂NTos, DMSO, K₂CO₃, 20 h, 100 °C; (d) CHCl₃, *t*-BuOK, benzene, 5.5 h, rt; (e) 2.10⁻⁵ mbar, 480 °C; (f) CHCl₃, C₁₉H₃₃N(CH₃)₃Br, ethanol, 50% NaOH, CH₂Cl₂, 18 h, 90 °C; (g) *t*-BuOK, DMSO, 2.5 h, rt.

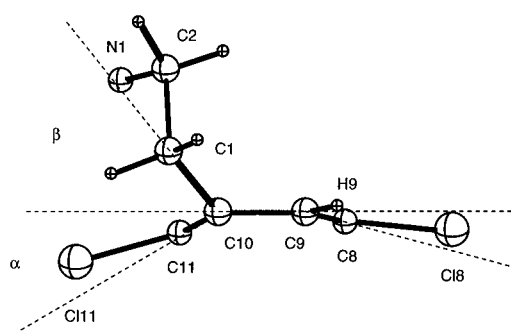

Figure 1. Side view of the crystal structure of **8**; the tosyl group at nitrogen has been omitted for clarity. Selected bond lengths (Å) and bond angles (deg) of **8**: C(1)–C(2) 1.560(4), C(2)–N(1) 1.486(4), C(8)–C(9) 1.371(5), C(9)–C(10) 1.385(4), C(10)–C(11) 1.399(4), C(1)–C(10) 1.504(4), C(10)–C(1)–C(2) 103.7(2), C(1)–C(2)–N(3) 114.9(2), C(2)–N(1)–C(4) 121.9(2); $\alpha = 27.4(3)^\circ$, $\beta = 48.7(2)^\circ$, $\gamma = 12.3(4)^\circ$.

carbons of the benzene ring is not significantly increased (48.7(2)° versus 48.0°). The total bending of the boat of the benzene ring of **8** ($\alpha + \gamma = 39.7^\circ$) as well as that of **1** ($\alpha + \gamma = 38.8^\circ$)¹ is practically identical to those of [6]paracyclophanes (38.9–41°).^{7a–c} Like in **1**, the bond distances in the cyclophane benzene ring of **8** have normal aromatic values (1.371(5)–1.399(4) Å): bond alternation is not observed. Note in particular that the molecule has *C_s* symmetry, therefore a distortion toward a cyclohexatriene structure can be excluded. Thus, contrary to our initial expectation, an increase in strain is not indicated by the distortion of the benzene ring.

The differences in the bridges of both cyclophanes are more striking. First of all, the ¹H NMR spectra taken both at room temperature and at –60 °C showed a frozen conformation of the bridge,⁸ with the nitrogen atom pointing away from the cyclophane benzene ring (see Figure 1; the eight-membered-ring containing the nitrogen possesses a chair–chair conformation). This is in contrast to the all-carbon analogue **1**, in which an 85:15 equilibrium between the chair–chair and the boat–

(1) Jennekens, L. W.; Klamer, J. C.; de Boer, H. J. R.; de Wolf, W. H.; Bickelhaupt, F.; Stam, C. H. *Angew. Chem.* **1984**, *96*, 236–237.

(2) (a) von Braun, J.; Neumann, L. *Chem. Ber.* **1919**, *52*, 2015–2019. (b) Shea, K. J.; Burke, L. D.; Doedens, R. J. *J. Am. Chem. Soc.* **1985**, *107*, 5305–5306.

(3) Ishino, Y.; Nishiguchi, I.; Kim, M.; Hirashima, T. *Synthesis* **1982**, 740–742.

(4) The spectroscopic and analytical data ($\pm 0.4\%$ for, C, H, Cl, and N) for all new compounds are in accord with the assigned structures (see Supporting Information).

(5) Baldew, A. U. Ph.D. Thesis, Vrije Universiteit, Amsterdam, The Netherlands, 1993; pp 102–103.

(6) Crystal data of **8**: C₁₇H₁₇NSO₂Cl₂, *M_r* = 370.30, orthorhombic, spacegroup *P2₁2₁2₁*, *a* = 6.7855(5) Å, *b* = 10.5456(4) Å, *c* = 23.4215(13) Å, *V* = 1675.98(17) Å³, *D_x* 1.4676(1) g cm⁻³, *Z* = 4, *T* = 150 K, *R* = 0.0478 for 3836 reflections with *I* > 2σ(*I*).

(7) (a) Krieger, C.; Liebe J.; Tochtermann, W. *Tetrahedron Lett.* **1983**, 707–710. (b) Tobe, Y.; Kakiuchi, Y.; Odaira, Y.; Hosaki, T.; Kai, Y.; Kasai, N. *J. Am. Chem. Soc.* **1983**, *105*, 1376–1377. (c) Tobe, Y.; Ueda, K.; Kakiuchi, Y.; Odaira, Y.; Kai, Y.; Kasai, N. *Tetrahedron* **1986**, *42*, 1851–1858.

(8) ¹H NMR (400 MHz, CDCl₃, rt): δ 7.56 (d, *J* = 8.3 Hz, 2 H), 7.17 (d, *J* = 8.3 Hz, 2 H), 6.67 (s, 2 H), 4.24 (A part of AB-system, *J_{AB}* = 13.1 Hz, *J* = 11.2 Hz, 3.1 Hz, 2 H), 3.73 (A part of AB-system, *J_{AB}* = 14.5 Hz, *J* = 2.7 Hz, 2.6 Hz, 2 H), 2.51 (B part of AB-system, *J_{AB}* = 13.0 Hz, *J* = 2.1 Hz, 1.9 Hz, 2 H), 2.32 (s, 3 H), 2.51 (B part of AB-system, *J_{AB}* = 14.5 Hz, *J* = 11.2 Hz, 2.2 Hz, 2 H).

chair conformations was observed at low temperature.⁹ The increased rigidity may be attributed to the shortening of the bridge caused by the shorter C–N bond lengths (1.486(4) Å in **8** versus 1.566(3) Å in **1**).¹ In **1**, the C–C–C bond angles in the bridge vary from 120° at the homobenzylic group to 122° at the central methylene group. This implies a large amount of angle strain for a bridge consisting of sp³-hybridized carbon atoms. In **8**, the C–C–N bond angle is 114.9(2)°, which indicates a decrease in angle strain at the homobenzylic methylene carbons. The C–N–C bond angle is 121.9(2)°, identical with the corresponding angle in **1**, but larger than the C–N–C bond angle of about 114° in the unstrained *N,N*-dimethyl-*p*-toluenesulfonamide.^{10a} Sulfonamides are more flexible than methylene groups in adjusting their bond angles; in the former, the C–N–C angles can range from 107° to 118.5° in both cyclic^{10 b–h} and acyclic^{10a,i} sulfonamides. The C–C–C bond angles at the benzylic carbon atoms (104.0° averaged), however, are nearly equal to those reported for **1** (104.7°).¹ In addition, the elimination of some H–H repulsion in the bridge when replacing a methylene group by a sulfonamide group will help in decreasing the total strain in the bridge.

This unpredicted decrease in overall strain of **8** compared to **1** is reflected in the high thermal stability and low (chemical) reactivity of **8**. In **1** and similar [5]metacyclophanes, the benzene ring undergoes Diels–Alder additions with dienophiles at room temperature as a consequence of considerable strain release.¹¹

(9) Turkenburg, L. A. M.; de Wolf, W. H.; Bickelhaupt, F.; Cofino, W. P.; Lammertsma, K. *Tetrahedron Lett.* **1983**, *24*, 1821–1824.

(10) (a) Häkkinen, A.-M.; Ruostesuo, P.; Kivekäs, R. *J. Chem. Soc., Perkin Trans. 2* **1988**, 815–820. (b) Gleiter, R.; Ritter, J.; Irgartinger, H.; Lichtenthaler, J. *Tetrahedron Lett.* **1991**, *32*, 2883–2886. (c) Vögtle, F.; Przybilla, K.-J.; Mannschreck, A.; Pustet, N.; Büllsbach, P.; Reuter, H.; Puff, H. *Chem. Ber.* **1988**, *121*, 823–828. (d) Paul, I. C.; Johnson, S. M.; Paquette, L.; Barrett, J. H.; Haluska, R. *J. Am. Chem. Soc.* **1968**, *90*, 5023–5023. (e) Groth, P. *Acta Chem. Scand.* **1984**, *A38*, 261–263. (f) Perst, H.; Massa, W.; Lumm, M.; Baum, G. *Angew. Chem.* **1985**, *97*, 859–860. (g) Prinzbach, H.; Bingmann, H.; Fritz, H.; Markert, J.; Knothe, L.; Eberbach, W.; Brokatzky-Geiger, J.; Sekutowski, J. C.; Krüger, K. *Chem. Ber.* **1986**, *119*, 616. (h) Beddoes, R. L.; Dalton, L.; Joule, J. A.; Mills, O. S.; Street, J. D.; Watt, C. I. F. *J. Chem. Soc., Perkin Trans. 2* **1986**, 784–797. (i) Ruostesuo, P.; Häkkinen, A.-M.; Kivekäs, R.; Sundberg, M. R. *J. Chem. Soc., Perkin Trans. 2* **1989**, 1397–1403.

Scheme 2^a

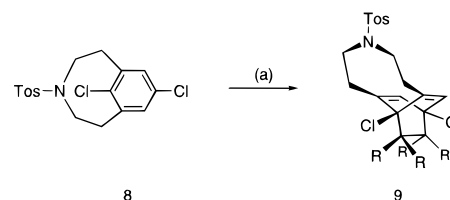

^a (a) TCNE, CDCl₃, rt, 12 h; R = CN.

When **8** was reacted with dienophiles such as dimethyl acetylenedicarboxylate (DMAD) or tetracyanoethylene (TCNE), either no reaction (DMAD) or a slow reaction (TCNE) was observed (Scheme 2). This is only partly due to the presence of the two chlorine substituents, since **1** also exhibits a lower reactivity than the parent [5]metacyclophane.¹² However, when TCNE (<1 equiv) was added to an NMR solution containing both **8** and **1**, the all carbon analogue **1** reacted more than five times faster than **8**. The most probable cause of the lack of reactivity of **8** must be the aforementioned relief of strain in the bridge, compared to that of **1**, since both the benzene rings of **8** and **1** display similar deformations from planarity.

Acknowledgment. The authors thank Dr. F. J. J. de Kanter and Dr. B. L. M van Baar for the 400 MHz NMR and HR-MS measurements, respectively. This work was financially supported by SON/NWO (N.V., A.L.S.).

Supporting Information Available: Experimental procedures and spectral data; tables of atomic coordinates, thermal parameters, bond lengths, and bond angles (17 pages). See any current masthead page for ordering and Internet access instructions.

JA9634987

(11) (a) Turkenburg, L. A. M.; Blok, P. M. L.; de Wolf, W. H.; Bickelhaupt, F. *Angew. Chem.* **1982**, *94*, 291–292. (b) Wijsman, G. W.; Van Es, D. S.; De Wolf, W. H.; Bickelhaupt, F. *Angew. Chem., Int. Ed. Engl.* **1993**, *32*, 726–728.

(12) Turkenburg, L. A. M.; de Wolf, W. H.; Bickelhaupt, F. *Tetrahedron Lett.* **1983**, *24*, 1817–1820.